



Suppliers to the **Education Sector**

Assembly Instructions

Tools

Philips Screwdriver

Allen Key (supplied)

Check List

Familiarise yourself with the contents

Check there is nothing missing

Check you have all the tools required

Make room to assemble the product

MAPLE BOOKCASE



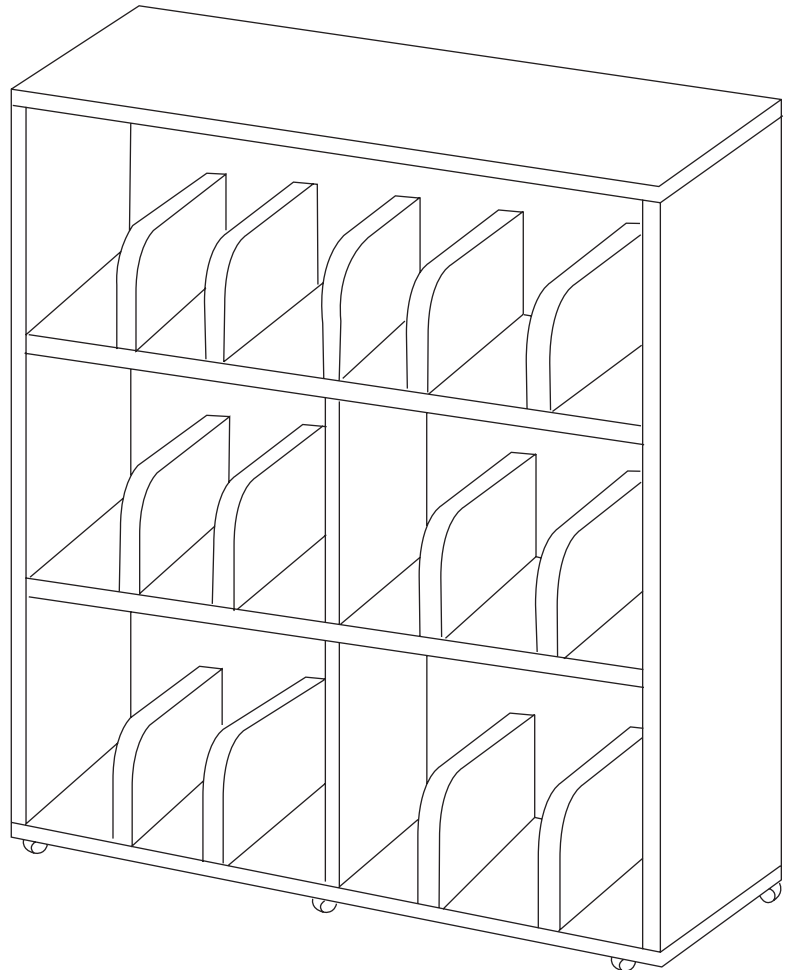

Code: MAPREDBK and MAPBLUBK





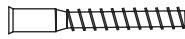

Before starting to assemble this unit please read the step by step assembly instructions carefully

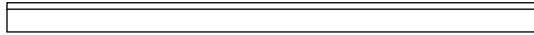
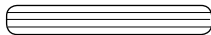

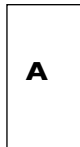
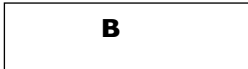
Help line

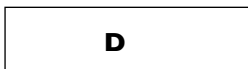
0151 479 3030

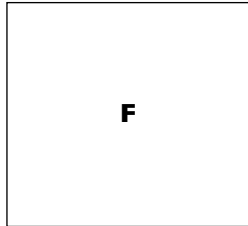
Components		Quantity
Conformat screws		46
1/2" x 8 Roundhead screw		24
Castor lockable		3
Castor freewheel		3
Label holder		3
6 x 30 dowels		4

Panels		Quantity	Size(mm)
	End	2	1055x338mm
	Top	1	1170x350mm
	Bottom	1	1170x340mm
	Shelf	2	1139x320mm
	Small dividers	13	280x155mm
	Back	1	1065x1150mm
	Large Dividers	2	341x280mm

IMPORTANT Panels lettered for identification if spare part is required. Please also state colour.

Step 1

Secure (6) castors to Bottom C using (24) 1/2 x 8 screws into 'Pop Marks' - lockable to front or rear.

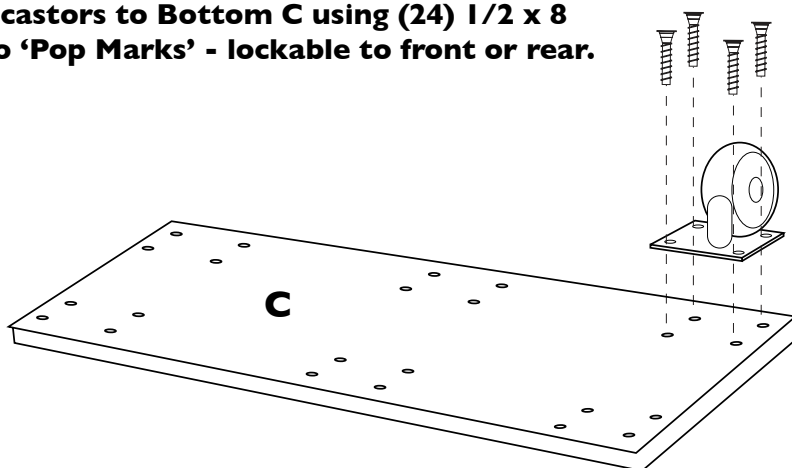

Step 2

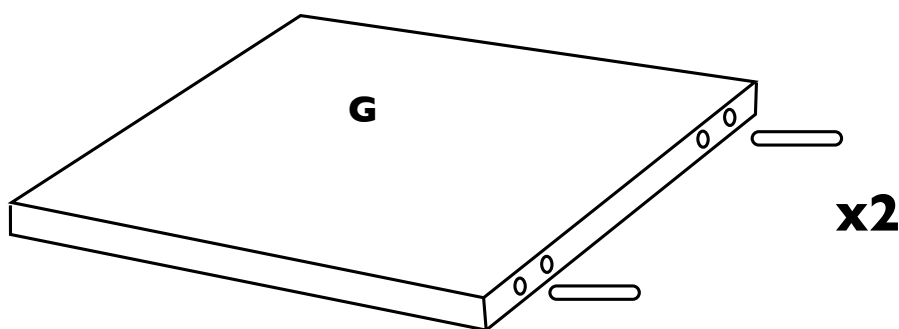

Insert (2) Dowels into Inner Holes in Dividers G

Step 3

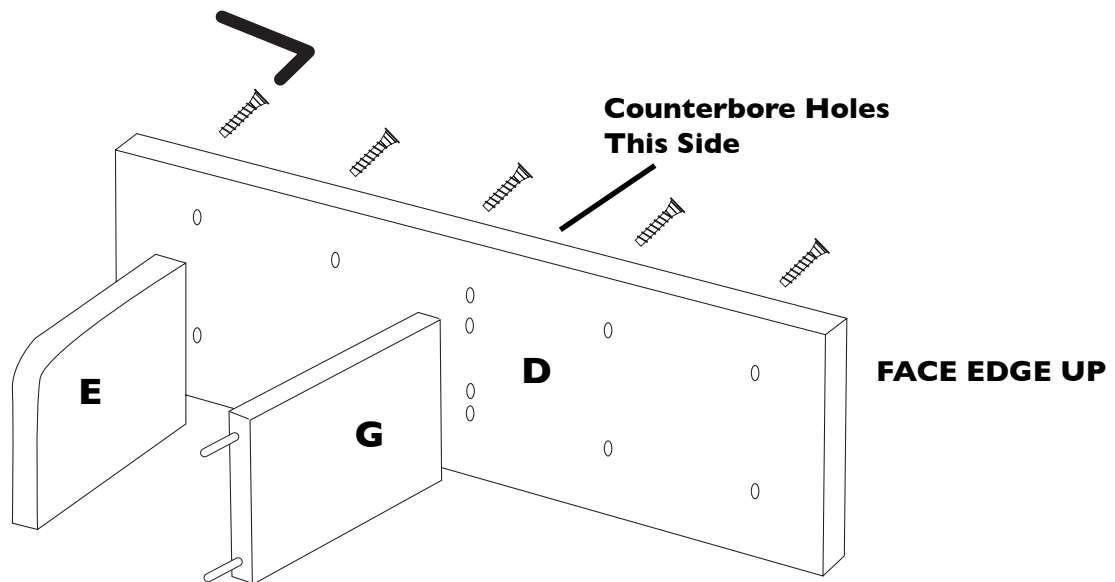

Secure 4 Dividers E and 1 Divider G to shelf D using (10) Conformat Screws

GROOVE ON BOTTOM C ONLY.

Step 4

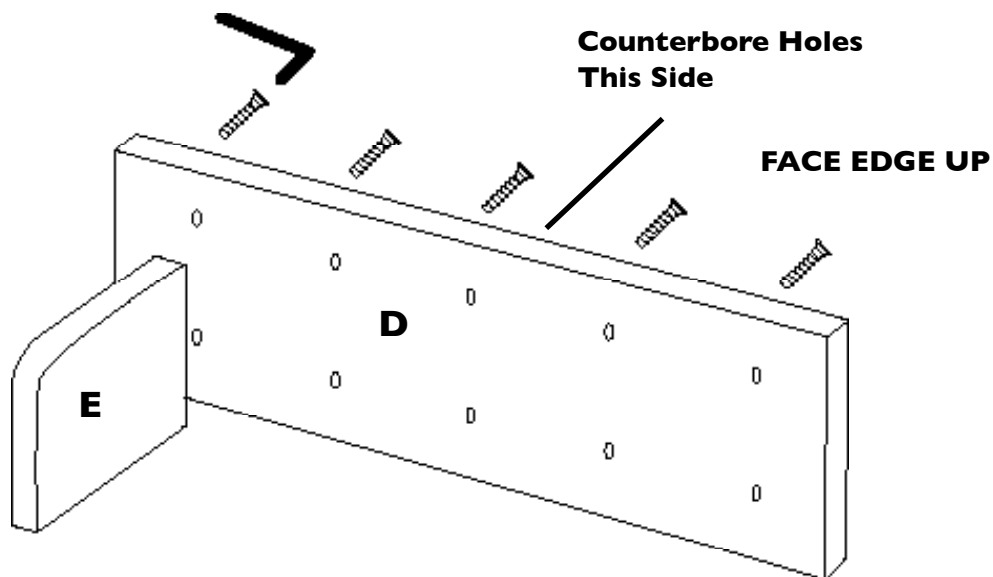

Secure 5 Dividers E to Shelf D using (10) Conformat Screws

Step 5

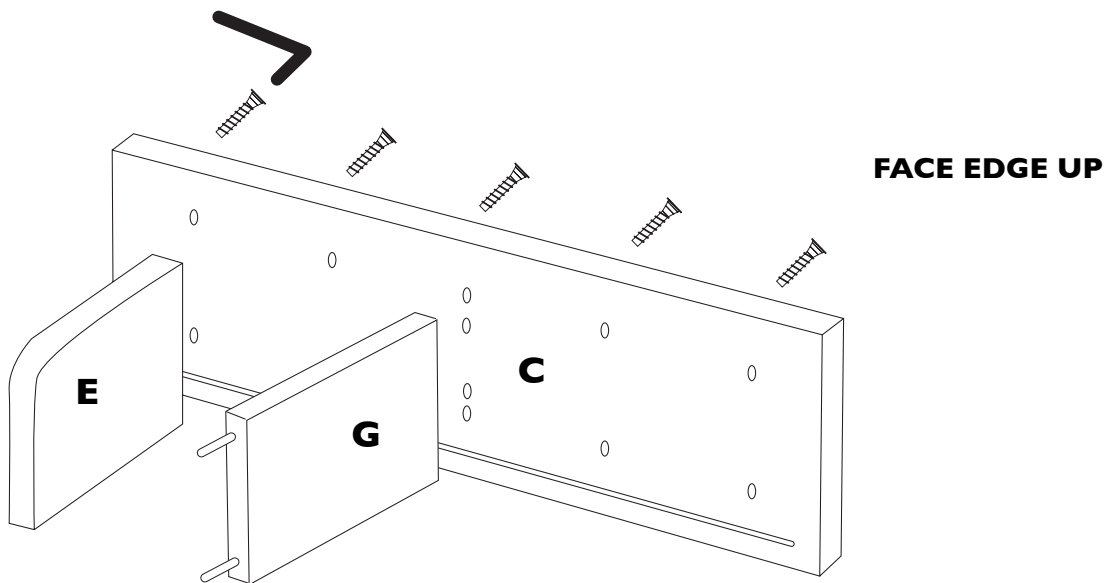

Secure 4 Dividers E and 1 Divider G to Bottom C using (10) Conformat Screws

Step 6

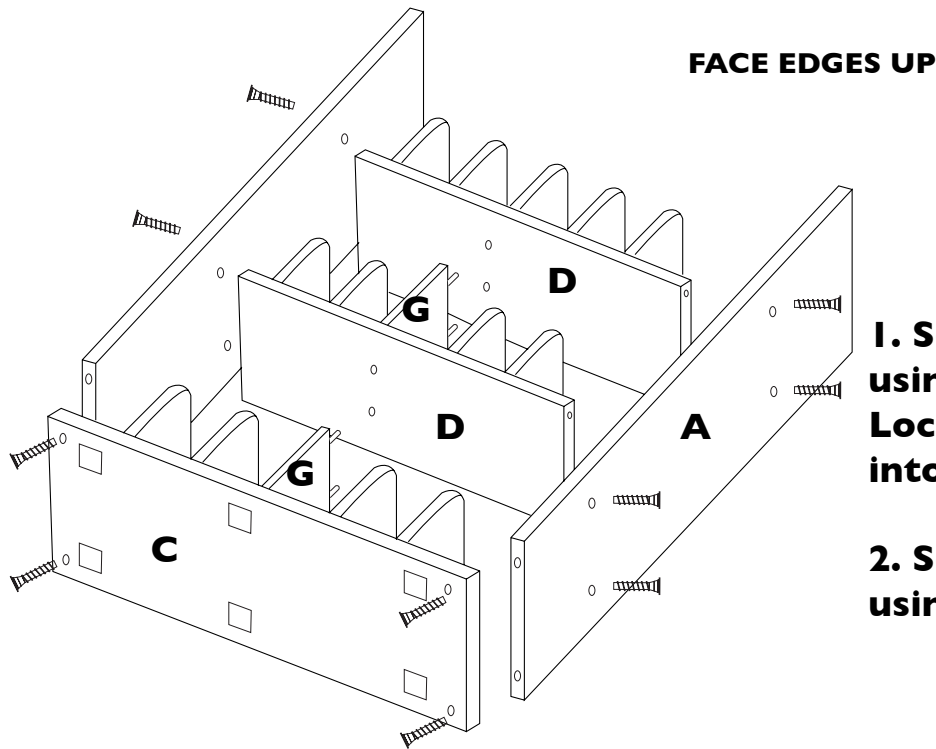

**1. Secure Bottom C to Ends A using (4) Conformat Screws
Locate dowels in Divider G into Center holes in Shelves D**

2. Secure Shelves D to Ends A using (8) Conformat Screws

Step 7

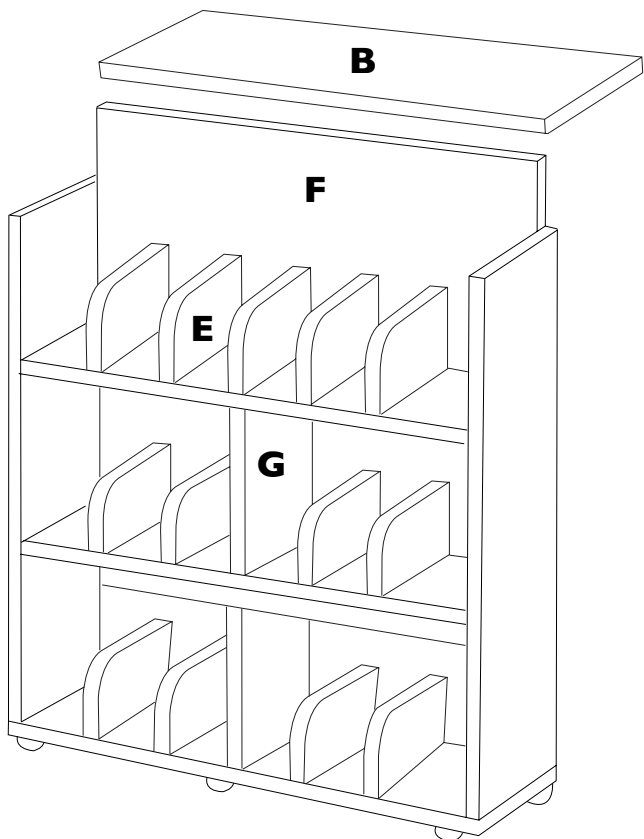

STAND UNIT UPRIGHT

1. Slide Back F into Grooves in Ends A

PLEASE make sure the GLOSSY SIDE is on the OUTSIDE

2. Secure Top B with (4) Conformat Screws into Ends A

3. Peel off backing paper and stick label holder onto Shelves D and Bottom C