

Tools

Allen Key (supplied)

Check List

Familiarise yourself with the contents

Check there is nothing missing

Check you have all the tools required

Make room to assemble the product

Assembly Instructions

Corner Filing Unit

Code: CFU-2

Before starting to assemble this unit please read the step by step assembly instructions carefully.

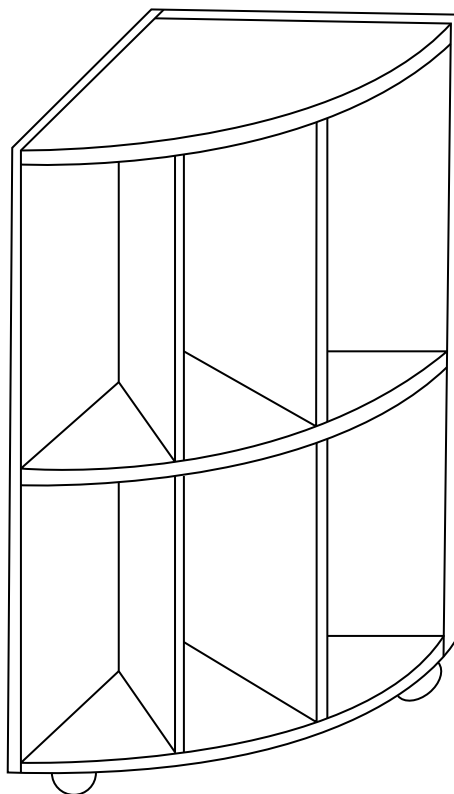

**Contact Number
0151 479 3030**

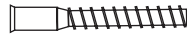
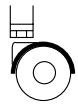
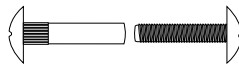
Components**Quantity****Confirmat Screws****12****Castor- Lockable****2****Castor- Freewheel****2****1/2 x 8 Screw****16****Allen Key****1****30mm x 6mm Dowel****16****Metal Connecting Bolts****2****Glue**

**IMPORTANT: APPLY A SMALL AMOUNT
OF GLUE INTO DOWEL HOLES BEFORE
DOWELS ARE INSERTED**

**Contact Number
0151 479 3030**

Profile Education

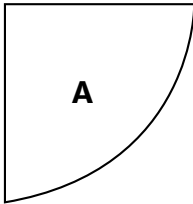
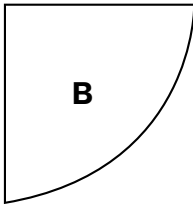
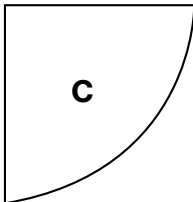
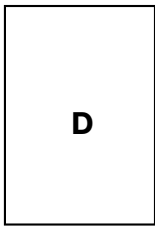
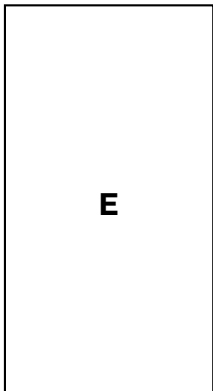
Panels	Quantity	Size (mm)
 A	1	445 X 445mm
Top & Bottom		
 B	1	445 X 445mm
 C	1	414.5 x 414.50mm
Shelf		
 D	4	372.5 x 280mm
Mid Ends		
 E	2	760 x 423mm
End		

Contact Number
0151 479 3030

Step 1

Secure Castors to panel B using (16) 1/2 x 8 screws. Note position of Lockable castors.

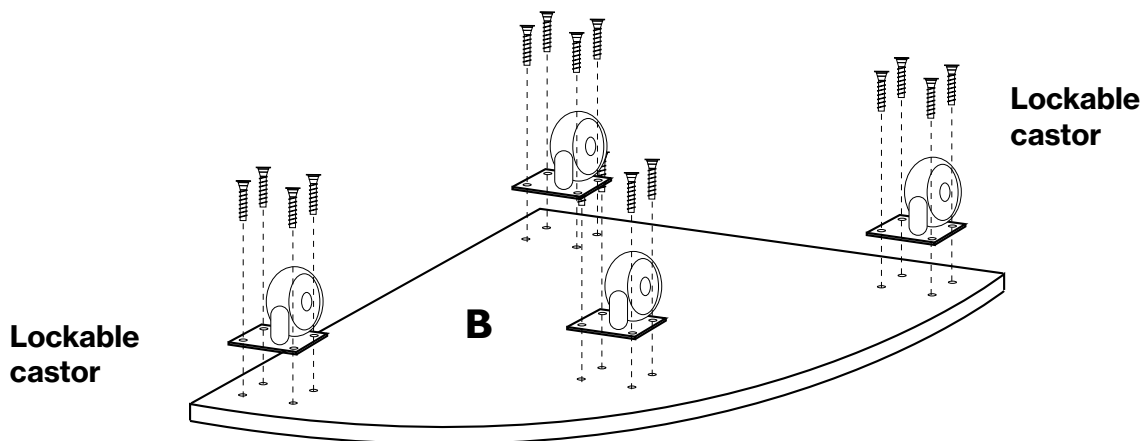

Step 2

Push dowels into holes. Tap dowels down until they reach the bottom of the holes.

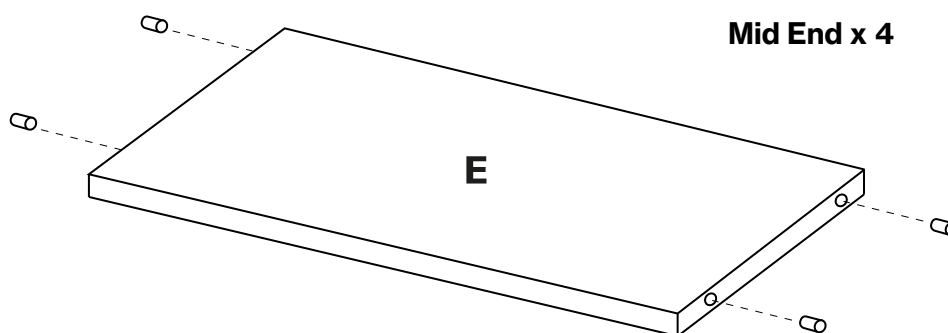

Contact Number
0151 479 3030

Step 3

Secure end to back panel using (2) confirmat screws.

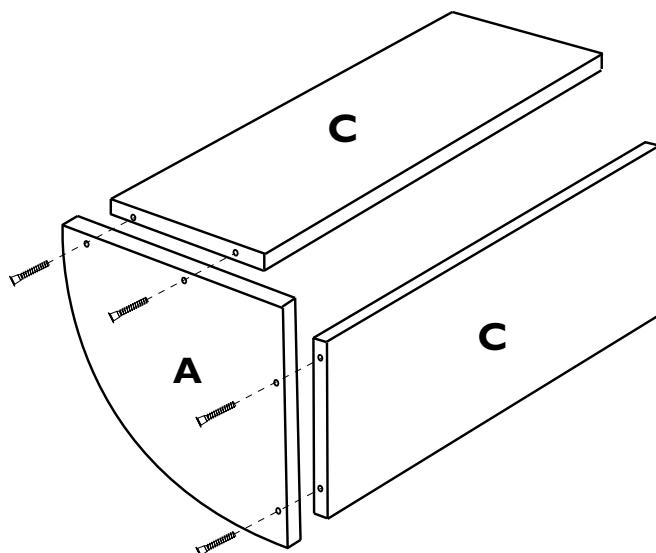

Step 4

Lay assembly on back. Secure bottom to end using (2) confirmat screws.

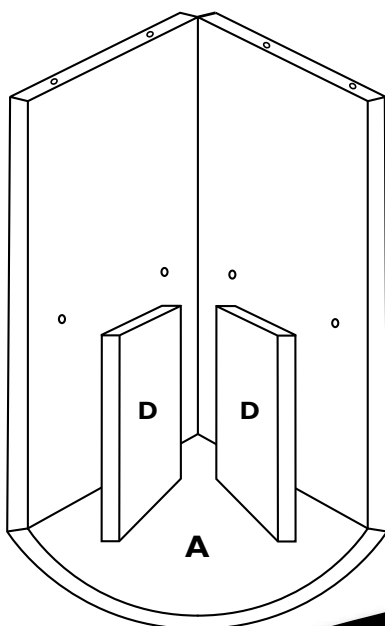

Contact Number
0151 479 3030

Step 5

Fit Shelf C onto dowels in Mid Ends D and secure with 4 confirmat screws.

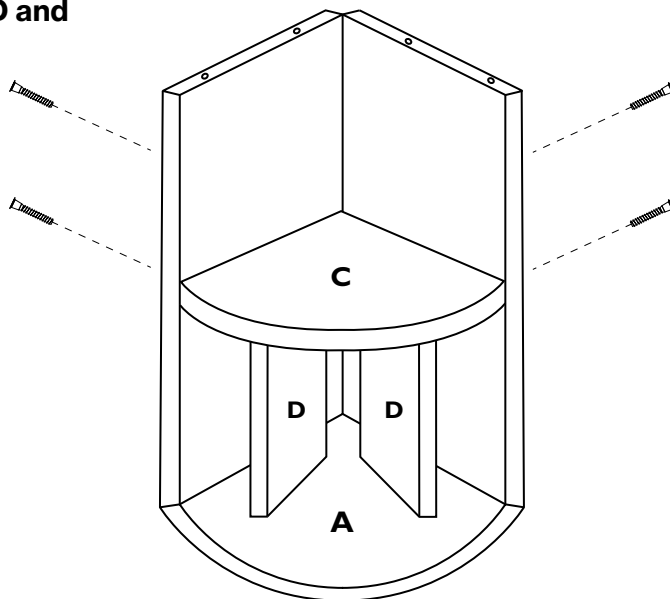

Step 6

Push two Mid Ends D into holes in Shelf C.

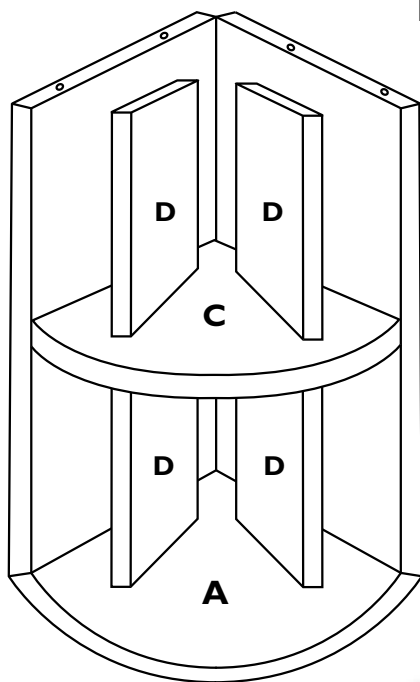

Contact Number
0151 479 3030

Step 7

Position Bottom B onto dowels in Mid Ends D and secure with (4) Confirmat screws.

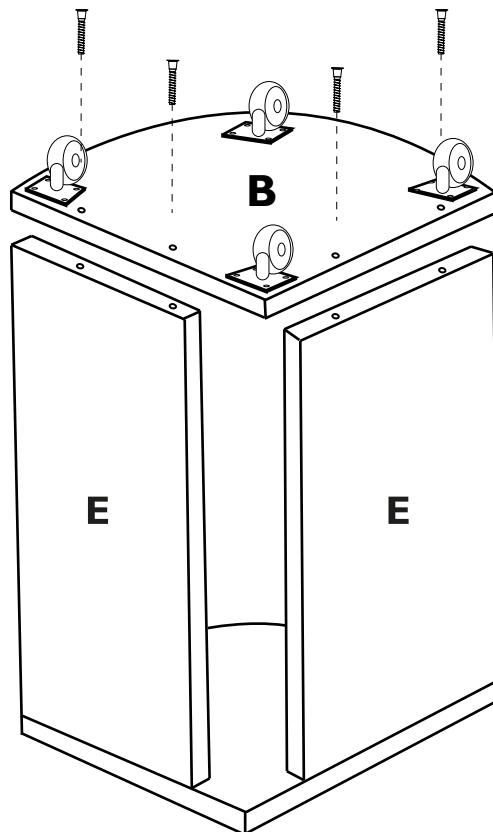

IMPORTANT: If using filing units side by side, ensure Top A is fitted so that the grain effect falls in the same direction. Units can then be bolted together through ends using connecting bolts.

YOUR UNIT IS NOW COMPLETE

Should you come across any problems, please call the
helpline below.

Contact Number
0151 479 3030

Castor Template

Use in 3 corners and centre of bottom Panel B.

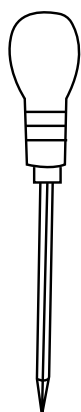
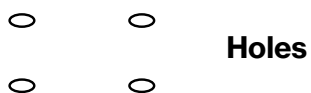

Bradawl

